

**Silicon Carbide
Schottky Diode Modules
100 Amperes / 3300 Volts**

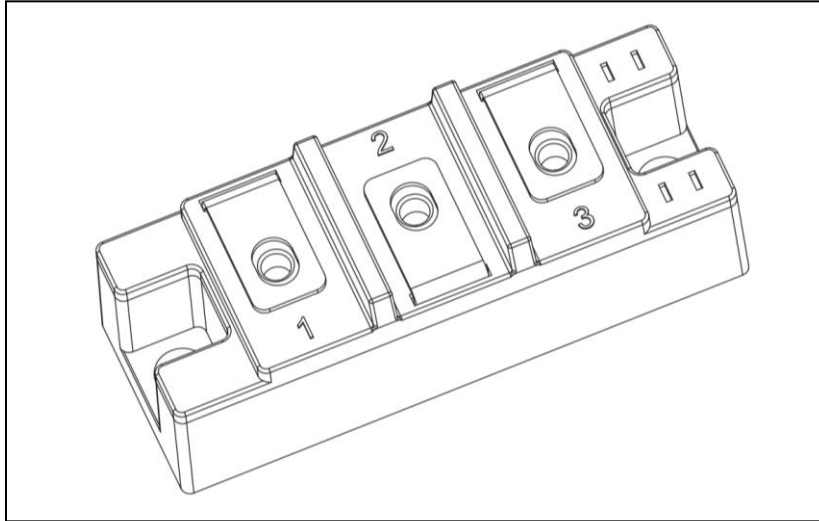

**Dual SiC Diode Module
100 Amperes / 3300 Volts**

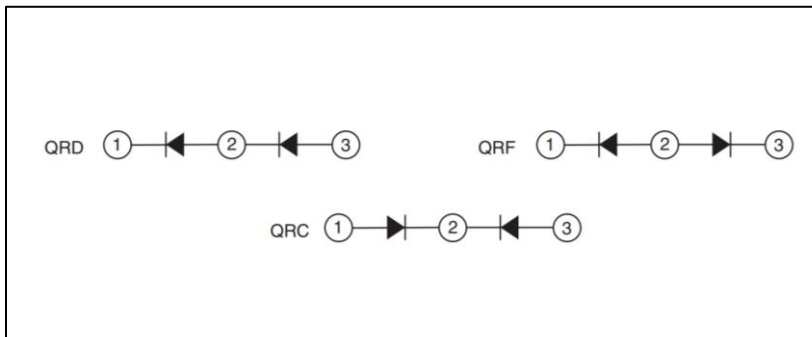

Description:

Powerex Silicon Carbide Dual Schottky Diode Modules are designed for use in applications requiring extremely fast switching. The modules are isolated for easy mounting with other components on common heatsinks.

Features:

- Junction Temperature: 175°C
- Extremely Fast Switching
- Zero Reverse Recovery
- Zero Forward Recovery
- High Frequency Operation
- Positive Temperature Coefficient on On-State Voltage (V_F)
- RoHS Compliant
- Isolated Mounting
- Metal Baseplate
- Low Thermal Impedance
- 6000V Isolation Voltage
- Aluminum Nitride Isolation

Applications:

- Energy Saving Power Systems
- High Frequency Type Power Systems
- High Temperature Power Systems
- Welding Converters
- Motor Control

Absolute Maximum Ratings, $T_j = 25^\circ\text{C}$ unless otherwise specified

Characteristics	Symbol	QR_3310SA1	Units
Repetitive Peak Reverse Blocking Voltage	V_{RRM}	3300	Volts
Non-Repetitive Peak Reverse Blocking Voltage	V_{RSM}	3300	Volts
DC Current, $T_C = 50^\circ\text{C}$ (Resistive Load) *2	$I_{F(DC)}$	100	Amperes
Non-Repetitive Forward Surge Current	I_{FSM}	200	Amperes
I^2t for Fusing for One Cycle ($t = 8.3\text{mS}$, 100% VRRM Reapplied)	I^2t	TBD	Amperes
Maximum Power Dissipation ($T_C=25^\circ\text{C}$, $T_J < 175^\circ\text{C}$) *1	P_D	319	Watts
Maximum Junction Temperature	T_{Jmax}	150	$^\circ\text{C}$
Operating Junction Temperature, Continuous operation (under switching)	T_{jop}	-40 to 150	$^\circ\text{C}$
Maximum Case Temperature*1	T_{cmax}	125	$^\circ\text{C}$
Storage Temperature	T_{stg}	-40 to 125	$^\circ\text{C}$
Mounting Torque, #10-32 Mounting Screws	--	3.5	N-m
Terminal Torque, #10-32 Terminal Screws	--	3.5	N-m
Module Weight (Typical)	--	180	Grams
Isolation Voltage	V_{ISO}	6000	Volts

*1 Case temperature (T_c) and heat sink temperature (T_s) are defined on the each surface (mounting side) of base plate and heat sink under the chips.

*2 Pulse width and repetition rate should be such that device junction temperature (T_j) does not exceed $T_{j(MAX)}$ rating.

DC Characteristics, $T_J=25^\circ\text{C}$ unless otherwise specified

Characteristics	Symbol	Test Conditions	Min.	Typ.	Max.	Units
Reverse Leakage Current	I_{RRM}	Rated V_{RRM}	-	-	1.0	mA
Forward Voltage (Chip)	V_{FM}	$I_F=100\text{A}$, $T_J = 25^\circ\text{C}$	-	2.02	-	Volts
		$I_F=100\text{A}$, $T_J = 150^\circ\text{C}$	-	2.41	-	Volts
Total Capacitive Charge	Q_C	$V_R=1800\text{V}$	-	1.47	-	μC
Stray Inductance	L_s	P-N	-	10	-	nH

Thermal Resistance Characteristics

Characteristics	Symbol	Test Conditions	Min.	Typ.	Max.	Units
Thermal Resistance, Junction to Case	$R_{th(j-c)}$	Per Diode	-	-	0.11	$^\circ\text{C/W}$
Contact Thermal Resistance	$R_{th(c-s)}$	Per Module, Thermal Grease Applied	-	0.07	-	$^\circ\text{C/W}$

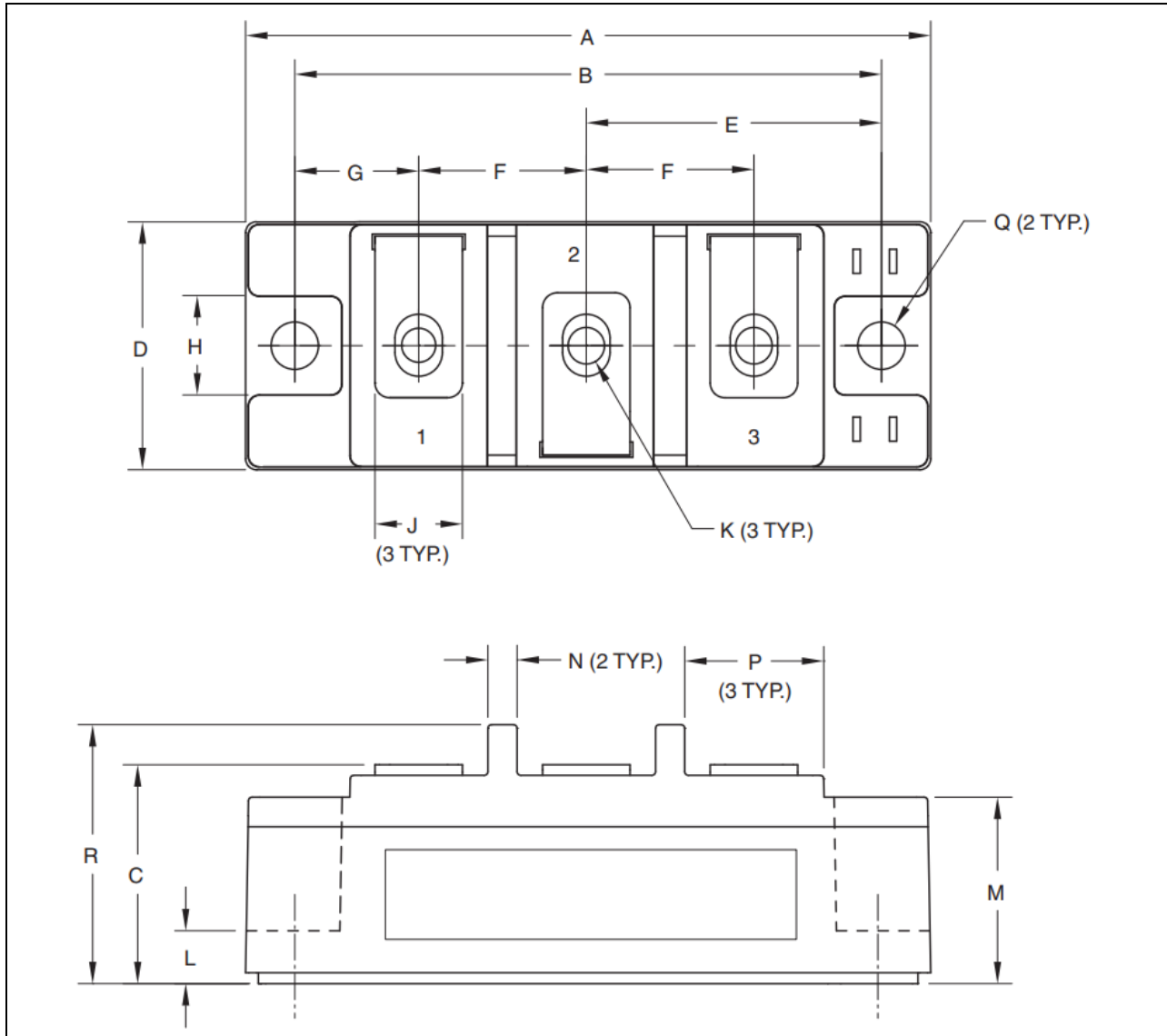

Dimensions	Millimeters
A	94
B	80
C	30
D	34
E	40
F	23
G	17
H	13

Dimensions	Millimeters
J	12
K	#10-32
L	7.5
M	25.4
N	4
P	19
Q	6.5 Dia.
R	35