

Description

VLA541 is a hybrid integrated circuit designed for driving n-channel IGBT modules in any gate-amplifier application. This device operates as an isolation amplifier for these modules and provides the required electrical isolation between the input and output with an opto-coupler.

Recommended IGBT modules:

$V_{CES} = 600V$ series up to 200A class

$V_{CES} = 1200V$ series up to 150A class

Features

- Electrical isolation between input and output with opto-coupler (Viso = 2500Vrms for 1minute)
- Two supply driver topology
- Built-in short circuit protection circuit (With a pin for fault out)
- CMOS compatible input interface

Applications

To drive IGBT modules for inverter or AC servo systems application

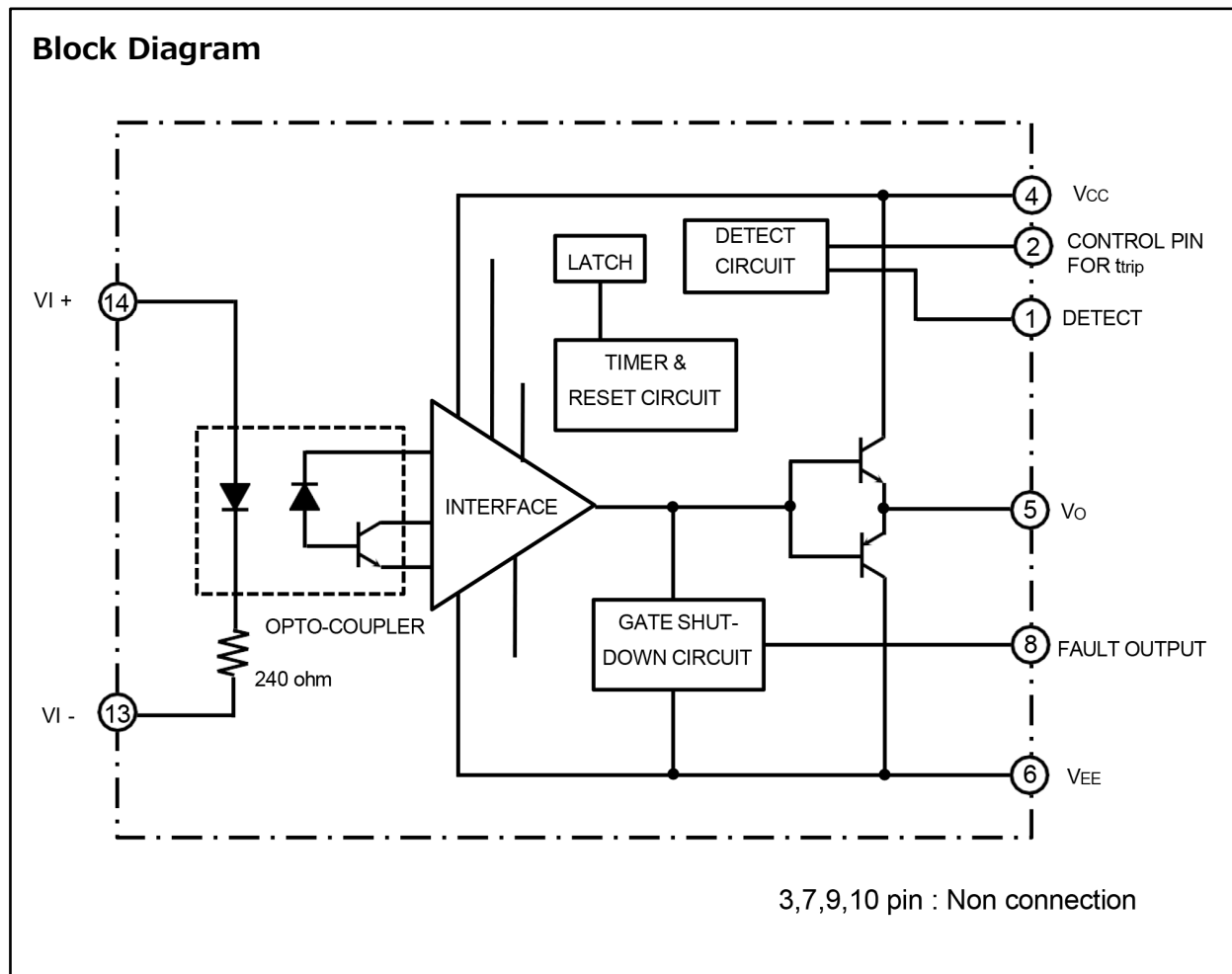

Maximum Ratings (Unless otherwise noted, Ta=25°C)

Symbol	Parameter	Conditions	Ratings	Unit
V _{CC}	Supply voltage	DC	18	V
V _{EE}			-15	V
V _I	Input signal voltage	Applied between; 13pin and 14pin 50% duty cycle, pulse width 1ms	-1 ~ +7	V
V _O	Output voltage	When the output voltage is "H"	V _{CC}	V
I _{OHP}	Output peak current	Pulse width 2us	-3	A
I _{OLP}			3	A
V _{iso}	Isolation voltage	Sine wave voltage 60Hz, for 1minute	2500	V _{rms}
T _C	Case temperature	-	95	°C
T _{opr}	Operating temperature	No condensation allowable	-20 ~ +70	°C
T _{stg}	Storage temperature	No condensation allowable	-40 ~ +100 (*1)	°C
I _{FO}	Fault output current	Applied 8pin	20	mA
V _{R1}	Input voltage at 1pin	Applied 1pin	50	V

(*1) Differs from H/C condition

Electrical Characteristics (Unless otherwise noted, $T_a=25^\circ\text{C}$, $V_{CC} = 15\text{V}$, $V_{EE} = -10\text{V}$, $R_G = 10\ \text{ohm}$)

Symbol	Parameter	Conditions	Limits			Unit
			Min	Typ	Max	
V_{CC}	Supply voltage	Recommended range	14	15	17	V
V_{EE}			-7	-	-12	V
V_{IN}	Pull-up voltage on primary side	Recommended range	4.75	5	5.25	V
I_{IH}	"H" input signal current	Recommended range	10	13	16	mA
f	Switching frequency	Recommended range	-	-	20	kHz
R_G	Gate resistance	Recommended range	3	-	-	ohm
I_{IH}	"H" input signal current	$V_{IN} = 5\text{V}$ HC04 drive	-	13	-	mA
V_{OH}	"H" output voltage	-	13	14	-	V
V_{OL}	"L" output voltage	-	-8	-9	-	V
t_{PLH}	"L-H" propagation time	$I_{IH}=13\text{mA}$	0.2	0.4	1	μs
t_r	"L-H" rise time	$I_{IH}=13\text{mA}$	-	0.3	1	μs
t_{PHL}	"H-L" propagation time	$I_{IH}=13\text{mA}$	0.2	0.4	1	μs
t_f	"H-L" fall time	$I_{IH}=13\text{mA}$	-	0.3	1	μs
t_{timer}	Timer	Between start and cancel (under input signal "OFF")	1	-	2	ms
I_{FO}	Fault output current	Applied 8pin, $R = 4.7\text{k ohm}$	-	5	-	mA
t_{trip1}	Controlled time detect short circuit 1	Pin1: 15V and more, Pin2:open	-	2.6	-	μs
t_{trip2}	Controlled time detect short circuit 2 (*2)	Pin1: 15V and more, Pin2-4:10pF (connective capacitance)	-	3	-	μs
V_{SC}	SC detect voltage	Collector voltage of IGBT module	15	-	-	V

(*1) Length of wiring of capacitor controlled time detect short-circuit is within 5cm from pin2 and pin4 coming and going.

Definition Of Characteristics

(1) SWITCHING OPERATION

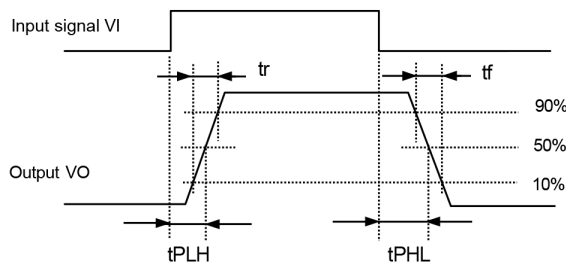

(2) SHORT CIRCUIT PROTECTION

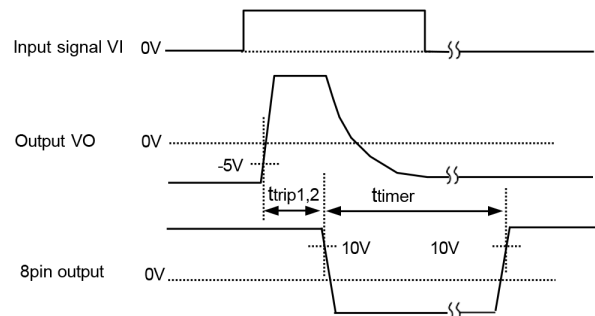

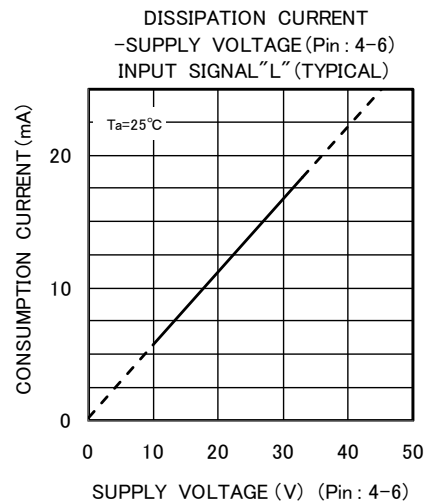
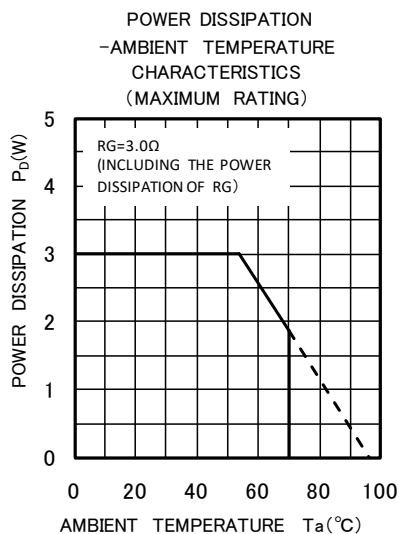
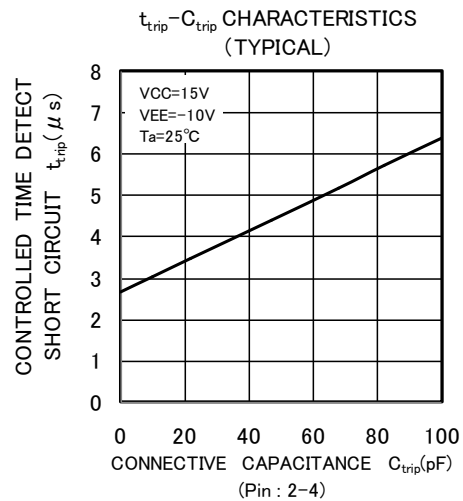
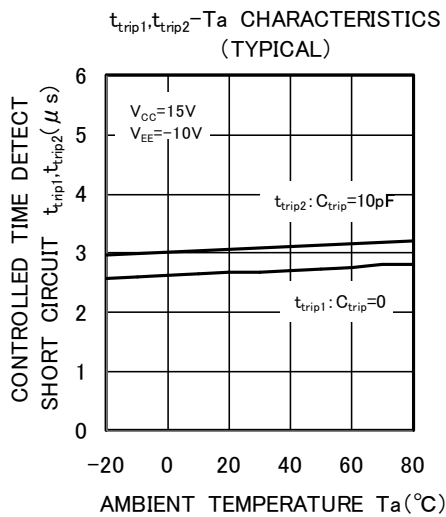
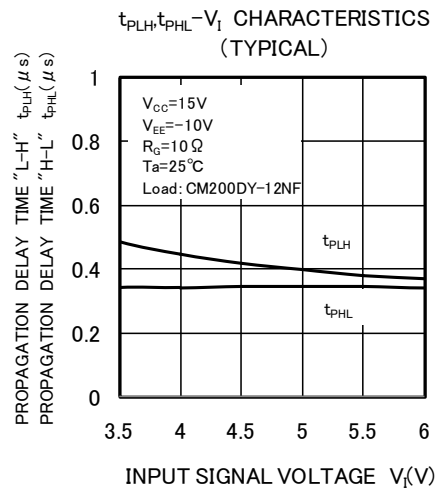
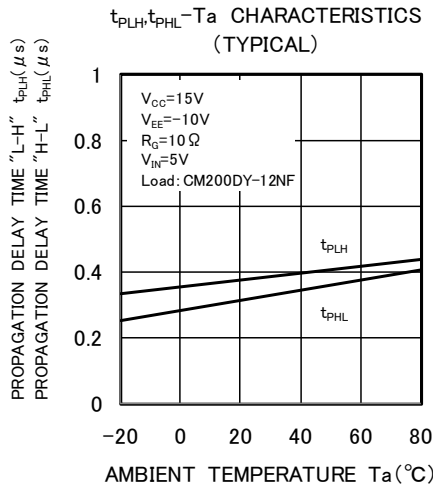
Performance Curves

Operation Of Protection Circuit

- 1) In case the gate voltage is "H" and the collector voltage is high, this hybrid IC will recognize the circuit as short circuit and immediately reduce the gate voltage. Besides, put out an error signal ("L") which inform that protection circuit is operating at the same time from pin8.
- 2) The protection circuit reset and resort to ordinary condition if input signal is "OFF" when the premised 1~2msec passed. ("OFF" period needs 10us or more)
- 3) When the output rises, the controlled time detect short circuit (Typ 2.6us) is set up so that on-time of IGBT can be secured properly.
 It is possible to adjust that time by connecting the capacitor (Ctrip) between pin2 and 4.

Application Circuit Example

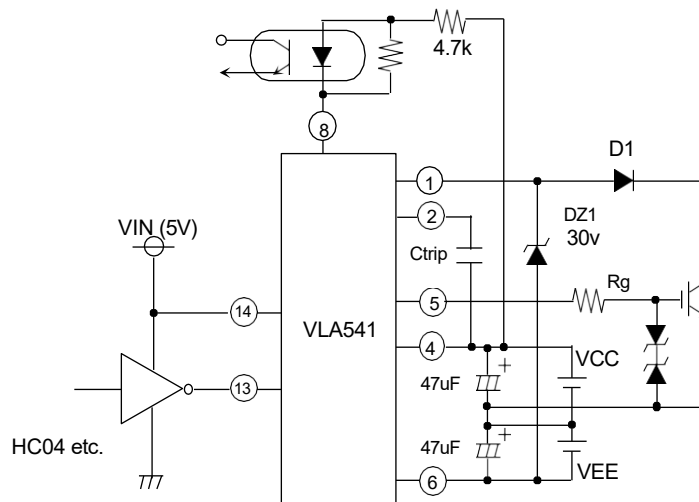

VCC = 15V VEE = 10V

Ctrip = 0 ~ 47pF (Rough guide , 50V,ceramic)

D1: Fast recovery diode (trr ≤ 0.2us)

RP1H (SanKen) etc.

Operation Flow On Detecting Short Circuit

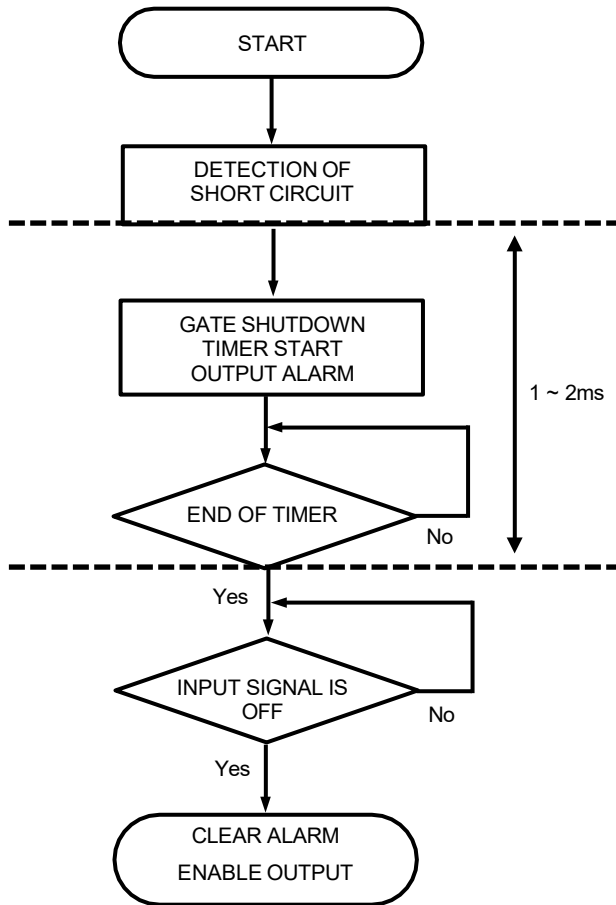

(*) Output voltage with protection circuit operating is about $-1V_{EE1}+2V$

Precaution

- 1) Voltage compensate capacitors are expected to be located as close as possible from the hybrid IC.
- 2) D1 requires approximately the same voltage of power modules.
- 3) If reverse recovery time of D1 is long, pin1 is applied high voltage. In that case, counterplan for protection which insert a zener diode between pin 1 and 6 is necessary like above diagram.
- 4) In case pin 2 is operating, the Ctrip is expected to be wired as close as possible from pin 2 and pin 4. (Less than 5cm coming and going)

Application Example Of Single Power Supply

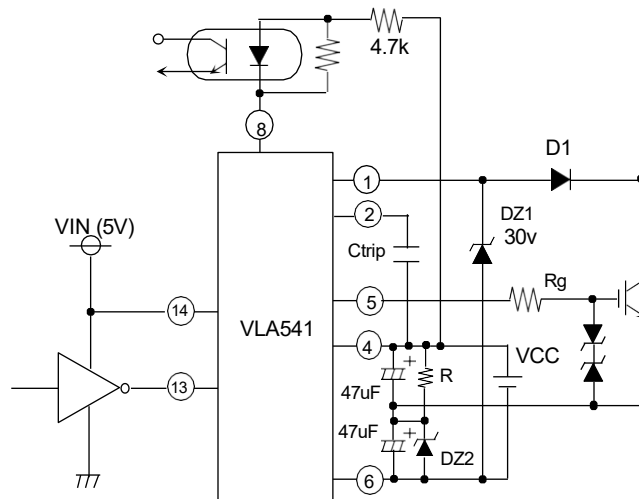

Vcc = 24V
R : 2.7k ~3.3kohm

DZ2 : 8.2V , 1/2W